

Temperature controller

Order number: 900410.025

As of: 18.01.2022 V1.18



Wiring diagram

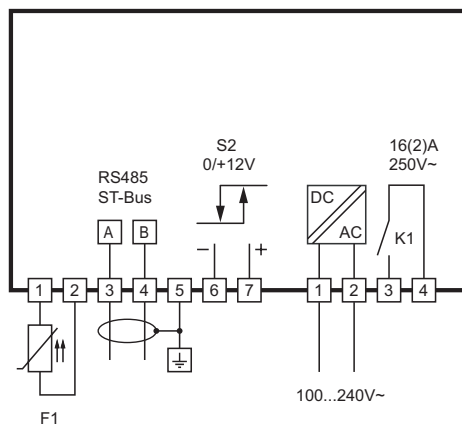

Product description

The controller ST24-FV1TUR.100 was developed for simple thermostatic applications. The unit disposes of a connection for resistance sensor PTC or Pt100. It is supplied with a voltage of 100...240V AC. The controller has a voltage output to control an external SSR relay and a relay with a maximum electric Ohm load of 16A. Inductive loads can be connected with up to max. 2.2A permanent current.

Networking of the controller takes place via the ST-Bus interface.

| | |
|-------------------------|-----------------------------|
| Sensor: | Multi resistance input |
| Measuring range: | dependent on type of sensor |
| Front size: | 107mm x 24mm |
| Panel cut-out: | 73mm x 22,4mm |
| Tightness: | Front IP65 |
| Connector: | screw terminal |

Operating keys



Key UP

By pressing this key, you can increase the parameter or parameter value or scroll the parameter list.



Key DOWN

By pressing this key, you can decrease the parameter or parameter value or scroll the parameter list. At alarm the buzzer function can be switched off with this key.



Key SET

Holding this key, the setpoint is indicated. Additionally, this key is used for setting parameters.

Another function can be assigned to the buttons with **H3 !...H33**, which is executed when pressed for a longer time (>3 sec.).

Control levels:

Parametrisation of the setpoint

The control setpoint **LT** is accessible directly with SET key.

Pressing also the UP or DOWN key it can be adjusted.

The activation of the second setpoint of circuit 1 **LT2** is indicated on the display with a flashing point to the right. It can either be activated via switching entrance or with a function key (depending on parameter).

Adjustment of control parameters

To activate parametrisation mode, press buttons UP and DOWN at the same time. After approx. 3 seconds, the code word **Adr** will be displayed. Press UP or DOWN to switch between code words **Adr** and **PR**.

Under code word **Adr** you can set a network address. This is required for commissioning networked systems.

By selecting code word **PR**, you can enter a password required for parametrisation. Once the password -19 has been entered, the name of the first group of parameters is displayed **C--** (controller level).

Now, using the buttons UP and DOWN you can select any of the parameter groups. After pressing the SET key you have to enter the password for the respective parameter level together with the UP and DOWN key. (Default value: 0)

The sub-menus are marked by the respective initial letter followed by 2 dashes (e.g. **C--** for the C-level).

| | Menu | Function |
|------------|------------------|--|
| C-- | Controller level | Application parameters |
| b-- | Between level | Linking parameters |
| H-- | Hardware level | Hardware parameters |
| d-- | Defrost level | Defrosting parameters |
| A-- | Analogue level | Parameter for analogue in- and outputs |

The last parameter of the respective sub-menu (e.g. **C99**, **b99**...) corresponds to the current password of this level and can be changed there.

NOTE: Forgetting the password requires sending the controller to Störk-Tronic.

After releasing the SET key, if the password is entered correctly, the display jumps to the sub-menu and shows the first parameter in the list. If you press the SET key, the value of the selected parameter is displayed. It can be adjusted by additionally pressing the UP or DOWN key. After releasing all keys, the new value is permanently stored.

If the UP and DOWN keys are pressed again simultaneously for at least 4 seconds, the display changes back to the menu level. Pressing again for 4 seconds or if no key is pressed for longer than 60 seconds, the display returns to the default state.

Software version

The version number of the software will show when pressing SET + UP + DOWN at the same time

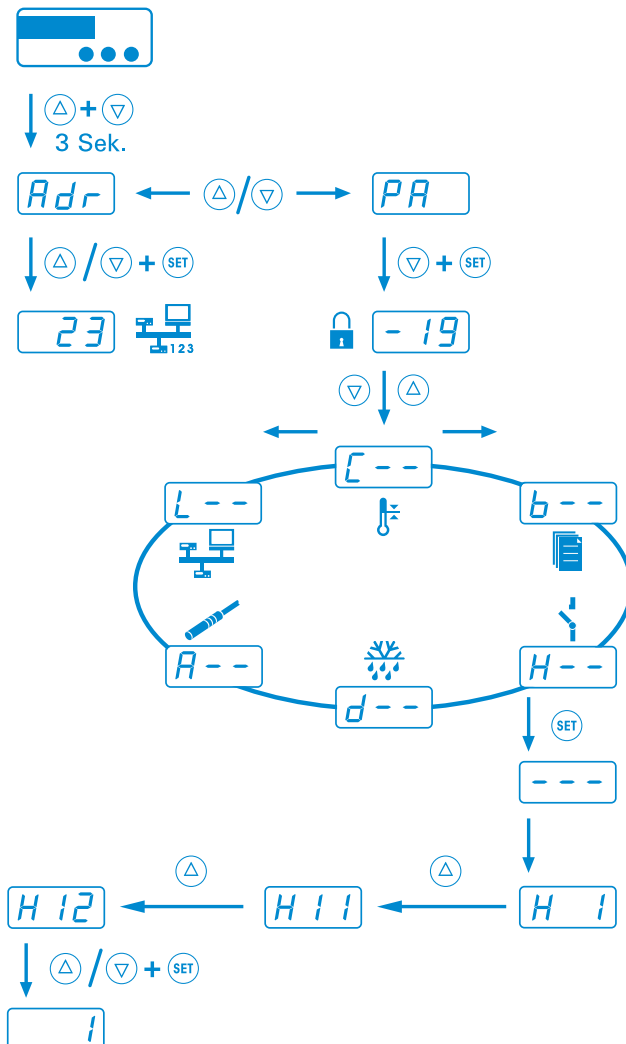

The C-level (controller)

This level contains the application parameters.

Thermostat 1

| Parameter | Function | Adjustment range | Standard value | Custom value |
|------------|--|--|----------------|--------------|
| C1 | Setpoint control circuit 1 | C10...C11 | 0.0 °C | |
| C2 | Setpoint control circuit 1 (*) | C10...C11 | 0.0 °C | |
| C3 | Offset for C1/C2 | -99.0 ... 99.0°K | 0.0 K | |
| C4 | Switching sense control circuit 1 | 0: heating function 1: cooling function | 1 | |
| C5 | Hysteresis control circuit 1 | 0.1 ... 99.9°K | 1.0 K | |
| C6 | Hysteresis mode control circuit 1 | 0: symmetrical 1: one-sided | 0 | |
| C7 | Minimum action time control circuit 1 "ON" | 0 ... 400 sec. | 0 sec. | |
| C8 | Minimum action time control circuit 1 "OFF" | 0 ... 400 sec. | 0 sec. | |
| C9 | Function control circuit 1 at sensor error | 0: relay off 1: relay on | 0 | |
| C10 | Control range limitation, minimum Setpoint 1, 2, 3 | -99.0°C ... C11 | -99.0 °C | |
| C11 | Control range limitation, maximum Setpoint 1, 2, 3 | C10 ... 999.0°C | 999 °C | |

* The activation of the second desired value **C2** is indicated on the display with a flashing point to the right. It can either be activated via switching entrance or with function key 1 (depending on parameter).

Thermostat 2

| Parameter | Function | Adjustment range | Standard value | Custom value |
|------------|---|--|----------------|--------------|
| C21 | Setpoint control circuit 2 (b1 =0) | C10...C11 | 0.0 °C | |
| C23 | Offset for C1/C21 (b1 =1) | -99.0 ... 99.0°K | 0.0 K | |
| C24 | Switching sense control circuit 2 | 0: heating function 1: cooling function | 1 | |
| C25 | Hysteresis control circuit 2 | 0.1 ... 99.9°K | 1.0 K | |
| C26 | Hysteresis mode control circuit 2 | 0: symmetrical 1: one-sided | 0 | |
| C27 | Minimum action time control circuit 2 "ON" | 0 ... 400 sec. | 0 sec. | |
| C28 | Minimum action time control circuit 2 "OFF" | 0 ... 400 sec. | 0 sec. | |
| C29 | Function control circuit 2 at sensor error | 0: relay off 1: relay on | 0 | |

Thermostat 3

| | | | | |
|------------|---|--|--------|--|
| C41 | Setpoint control circuit 3 (b2 =0) | C10...C11 | 0.0 °C | |
| C43 | Offset for C1/C41 (b2 =1) | -99.0 ... 99.0°K | 0.0 K | |
| C44 | Switching sense control circuit 3 | 0: heating function 1: cooling function | 1 | |
| C45 | Hysteresis control circuit 3 | 0.1 ... 99.9°K | 1.0 K | |
| C46 | Hysteresis mode control circuit 3 | 0: symmetrical 1: one-sided | 0 | |
| C47 | Minimum action time control circuit 3 "ON" | 0 ... 400 sec. | 0 sec. | |
| C48 | Minimum action time control circuit 3 "OFF" | 0 ... 400 sec. | 0 sec. | |
| C49 | Function control circuit 3 at sensor error | 0: relay off 1: relay on | 0 | |

Boundary or range alarm

| | | | | |
|------------|-------------------|-------------------------|----------|--|
| C61 | Lower alarm value | -99.0 ... C62 °C | -10.0 °C | |
| C62 | Upper alarm value | C61 ... 999.0 °C | 10.0 °C | |

| Parameter | Function | Adjustment range | Standard value | Custom value |
|-----------------|------------------------------------|--|----------------|--------------|
| €63 | Alarm functions | 0: Boundary alarm, relative boundaries 1: Boundary alarm, absolute boundaries 2: Range alarm, relative boundaries 3: Range alarm, absolute boundaries 4: Boundary alarm, relative boundaries, alarm inverse 5: Boundary alarm, absolute boundaries, alarm inverse 6: Range alarm, relative boundaries, alarm inverse 7: Range alarm, absolute boundaries, alarm inverse | 0 | |
| €64 | Special function at boundary alarm | 0: not active 1: flashing display 2: buzzer 3: buzzer + flashing display 4: like 3, buzzer can be cancelled 5: like 4, restarts after 10 min. 6: like 4, restarts after 30 min | 0 | |
| €65 | Hysteresis alarm circuit | 0.1 ... 99.9 K | 1 K | |
| Password | | | | |
| €99 | Password C level | -99...999 | 0 | |

b-level (between)

This level contains the parameters for different combinations.

| Parameter | Function | Adjustment range | Standard value | Custom value |
|------------|---|--|----------------|--------------|
| b1 | Activation setpoint combination for thermostat 1 and 2 (€23 = deltaW2) | 0: no combination 1: Setpoint thermostat 2 = $\frac{1}{€2} + €23$ | 0 | |
| b2 | Activation setpoint combination for thermostat 1 and 3 (€43 = deltaW3) | 0: no combination 1: setpoint thermostat 3 = $\frac{1}{€2} + €33$ | 0 | |
| b11 | Delay control circuit 1, 2, 3 after "Power-On" | 0...400 sec. | 0 sec. | |
| b12 | Mutual delay control circuit 1, 2, 3 | 0...400 sec. | 0 sec. | |
| b13 | Alarm suppression after "Power-On", "setpoint" | 0...60 min. | 20 min. | |
| b21 | Linking analogue exit | 0: actuating variable 1: actual value 2: setpoint | 0 | |
| b99 | Password b-level | -99 ... 999 | 0 | |

H level (Hardware)

This level contains the hardware parameters.

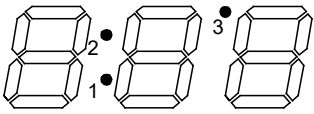
| Parameter | Function | Adjustment range | Standard value | Custom value |
|-----------|--|---|----------------|--------------|
| H 1 | Key-lock | 0: no key-lock 1: key-lock | 0 | |
| H 11 | Indication mode display 1 | 0: integrals 1: decimals in 0.5°K 2: decimals in 0.1°K | 1 | |
| H 12 | Display 1 mode | 1: actual value 2: setpoint | 1 | |
| H 15 | Temperature scale | 0: Celsius 1: Fahrenheit | 0 | |
| H 16 | Indication standby | 0: no display (point to the right) 1: AUS 2: OFF 3: display off, right point flashing | 1 | |
| H 17 | Mode following "Power-On" " | 0: Off 1: On 2: Auto | 1 | |
| H3 1 | Assigning function key 1 | 0: no function 1: standby key 2: defrosting | 2 | |
| H32 | Assigning function key 2 (if available) | 0: no function 1: standby key 2: defrosting | 2 | |
| H33 | Assigning function key 3 (if available) | 0: no function 1: standby key 2: defrosting | 0 | |
| H35 | Activation of key acknowledgement | 0: no key acknowledgement 1: key acknowledgement with buzzer | 0 | |
| H4 1 | Function output K1 | 0: no connection 1: thermostat 1 2: thermostat 2 3: thermostat 3 4: alarm function 5: reserved 6: reserved 7: on, if controller on | 1 | |
| H42 | Function output S2 | see H4 1 | 0 | |
| H43 | n/a | - | 0 | |
| H44 | n/a | - | 0 | |
| H5 1 | Mains frequency | 0: 50Hz 1: 60Hz | 0 | |
| H6 1 | Function LED 1  | 0: inactive 1: output thermostat 1 2: defrost 3: flash during defrost 4: output thermostat 2 5: output thermostat 3 6: relay K1 7: output S2 | 0 | |
| H62 | Function LED 2 | see H6 1 | 1 | |
| H63 | Function LED 3 | see H6 1 | 0 | |
| H99 | Password H level | -99..999 | 0 | |

d-level (defrosting functions)

This level contains the parameters for defrosting.

NOTE: Defrosting parameter only affects control circuit 1

| Parameter | Function | Adjustment range | Standard value | Custom value |
|-----------|----------------------------|-----------------------------------|----------------|--------------|
| d0 | Defrosting interval TH1 | 1 ... 99h 0: no defrosting | 0 | |
| d2 | Defrosting temperature TH1 | -99.0 ... 999.0°C | 10,0 °C | |
| d3 | Defrosting time limit TH1 | 1 ... 99 min. 0: no time limit | 30 min | |
| d9 | Manual defrosting TH1 | 0...1 | 0 | |
| d99 | Password d-level | -99...999 | 0 | |

Die A-level (analogue values)

This level contains the parameters for analogue inputs and outputs

| Parameter | Function | Adjustment range | Standard value | Custom value |
|-----------|----------------------------|---|----------------|--------------|
| R1 | Actual value sensor F1 | - | | |
| R2 | Actual value correction F1 | -99.0 ... 99.9 °K | 0 K | |
| R3 | Weighing factor F1 | 0.50 ... 1.50 | 1,00 | |
| R4 | Sensor type F1 | 0: non existent 1: PTC 2: Pt100 2-wire | 1 | |
| R17 | Reset min/max memory | 0: - 1: reset MAX memory 2: reset MIN memory 3: reset MAX+MIN memory | 0 | |
| R18 | Show actual MAX value | — | | |
| R19 | Show actual MIN value | — | | |
| R40 | Software filter | 1...32 measuring values | 4 | |
| R99 | Password A-level | -99 ... 999 | 0 | |

Z-level (additional level)

Parameters are only accessible via ST-Bus.

| Parameter | Function | Adjustment range | Standard value | Custom value |
|-----------|--|--|----------------|--------------|
| J1 | Parameter set | 0...1 | 0 | |
| J3 | Parameter reset | 0: - 1: only control parameters 2: like 1, including passwords | 0 | |
| L0 | Own ST-Bus address | 0: deactivated 1...250 | 5 | |
| Pro | Show program version | — | | |
| L40 | Release mask for ST-Bus (functions) | 0...255 | 0 | |
| L42 | 10 minutes release to reset counters and operating times | 0: locked 1: Enable Reset for 10 minutes (see N98 and T98) | 0 | |
| Z98 | Password for level selection (if PA is displayed) | -99 ... 999 | -19 | |
| Z99 | Password for Z-level | -99 ... 999 | 0 | |

N-level (counters)

Parameters are only accessible via ST-Bus.

| Parameter | Function | Adjustment range | Standard value |
|-----------|---------------------------------------|-------------------|----------------|
| N0 | Switching cycles of K1 (lower 16 bit) | — | |
| N1 | Switching cycles of K1 (upper 16 bit) | — | |
| N2 | Switching cycles of S2 (lower 16 bit) | — | |
| N3 | Switching cycles of S2 (upper 16 bit) | — | |
| N98 | Delete relay switching cycles | 0: — 1: delete | 0 |
| N99 | Password for Z-level | -99 ... 999 | 0 |

The number of switching cycles is calculated as follows: Number = 65536 * N1 + N0. Parameter N98 resets all relay switching cycle counters. It depends on the setting in parameter [L42](#). The return value is automatically set back to 0.

T-level (operating times)

Parameters are only accessible via ST-Bus.

| Parameter | Function | Adjustment range | Standard value |
|-----------|---|------------------|----------------|
| T0 | Overall operating time (lower 16bit) | — | |
| T1 | Overall operating time (upper 16bit) | — | |
| T2 | Operating time since last reset (lower 16bit) | | |
| T3 | Operating time since last reset (upper 16bit) | | |
| T4 | Operating time relay K1 (lower 16bit) | | |
| T5 | Operating time relay K1 (upper 16bit) | | |
| T6 | Operating time relay S2 (lower 16bit) | | |
| T7 | Operating time relay S2 (upper 16bit) | | |
| T98 | Reset operating hours | 0: — 1: Reset | 0 |
| T99 | Password for T-level | -99 ... 999 | 0 |

The operating time is calculated as follows, for example: Operating time (in min.) = 65536 * T1 + T0. Parameter T98 resets all operating and running times (except T0 and T1). It depends on the setting in parameter [L42](#). The return value is automatically set back to 0.

EC - level (only for internal use)

Parameters are only accessible via ST-Bus.

C-level:

[1]: Setpoint control circuit 1

This value corresponds with the setpoint set at the first control level.

[2]: Setpoint control circuit 1 (thermostat) at closed switching input

By closing switching input E1, setpoint [1] can be switched to a setpoint [2].

The setpoint [2] can only be accessed if entrance E1 is closed. It can only be activated, if the external input is configured for setpoint change-over.

[3]: Offset for [1]/[2]

This adjusted value will build the difference to the setpoint for control circuit 1, i.e. there is no regulation according to the pre-set value, but according to the sum of desired value and the value of [3].

[4]: Switching sense control circuit 1

The switching sense for the relays, i.e. cooling or heating function, can be programmed independently. Heating function means that the contact falls as soon as the pre-set setpoint is reached, thus power interruption. At cooling function, the contact only tightens, if the actual value is above the required setpoint.

[5]: Hysteresis control circuit 1

The hysteresis can be set symmetrically or one-sided at the desired value (see [6]). At one-sided setting, the hysteresis works downward with heating contact and upward with cooling contact. At symmetrical hysteresis, half of the hysteresis' value is effective below and half of the value above the switching point.

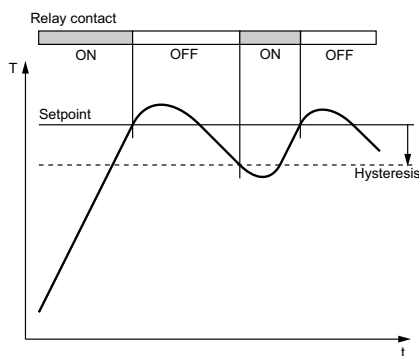

Heating controller, one-sided hysteresis

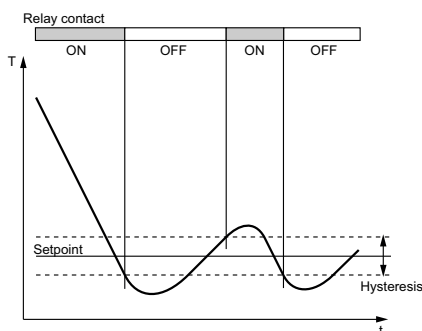

Cooling controller, one-sided hysteresis

[6]: Hysteresis mode control circuit 1

These parameters allow selection as to whether the hysteresis values which are adjustable with [5], are set symmetrically or one-sided at the respective switching point. At symmetrical hysteresis, half of the hysteresis' value is effective below and half of the value above the switching point. The one-sided hysteresis works downward with heating contact and upward with cooling contact.

[7]/[8]: Minimum action time control circuit 1 "On"/"Off"

These parameters permit a delay in switching on/off the relay in order to reduce the switching frequency. The adjusted time sets the entire minimum time period for a switching-on or switching-off phase

[9]: Function circuit 1 at sensor error

At sensor error the selected relay (see H41, H42) falls back into the condition pre-set here.

[10]: Setpoint limit (min) setpoint 1

[11]: Setpoint limit (max) setpoint 1

The adjustment range of the setpoint can be limited in both directions. This is to prevent the end user of a unit from setting inadmissible or dangerous setpoints.

[12]: Setpoint control circuit 2 (thermostat) (b1=0)

If b1=1, this value is ineffective.

[23]: Value deltaW2 (b1=1)

If b1=1, the setpoints for control circuit 1 and 2 are linked with one another via switching difference deltaW2 (operation with deltaW).

The following applies: Setpoint thermostat 2 = setpoint control circuit 1 ([1]/[2]) + deltaW2.

This difference can take positive or negative values. Thus, a leading or following contact can be realised.

[24]: Switching sense control circuit 2

The switching sense for the relays, i.e. cooling or heating function, can be programmed independently at works. Heating function means that the contact falls as soon as the pre-set setpoint is reached, thus power interruption. At cooling function, the contact only tightens, when the actual value is above the required setpoint.

[25]: Hysteresis control circuit 2

The hysteresis can be set symmetrically or one-sided at the setpoint (see [26]). At one-sided setting, the hysteresis works downward with heating contact and upward with cooling contact. At symmetrical hysteresis, half of the hysteresis' value is effective below and half of the value above the switching point.

[26]: Hysteresis mode control circuit 2

These parameters allow selection as to whether the hysteresis values which are adjustable with [25], are set symmetrically or one-sided at the respective switching point. At symmetrical hysteresis, half of the hysteresis' value is effective below and half of the value above the switching point. The one-sided hysteresis works downward with heating contact and upward with cooling contact.

[27]: Minimum action time control circuit 2 "On"

[28]: Minimum action time control circuit 2 "Off"

These parameters permit a delay in switching on/off the relay, in order to reduce the switching frequency. The adjusted time sets the entire minimum time period for a switching-on or switching-off phase.

[29]: Function control circuit 2 at sensor error

At sensor error the selected relay (see H41, H42) falls back into the condition pre-set here.

[41]: Setpoint thermostat 3 (b2=0)

If b2=1, this value is ineffective.

[43]: Value deltaW3 (b2=1)

If b2=1, the setpoints for control circuit 1 and 2 are linked with one another via switching difference deltaW3 (operation with deltaW).

The following applies: Setpoint thermostat 3 = setpoint control circuit 1 ([1]/[2]) + deltaW3.

This difference can take positive or negative values. Thus, a leading or following contact can be realised.

[44]: Switching sense control circuit 2

The switching sense for the relays, i.e. cooling or heating function, can be programmed independently at works. Heating function means that the contact falls as soon as the pre-set setpoint is reached, thus power interruption. At cooling function, the contact only tightens, when the actual value is above the required setpoint.

[45]: Hysteresis control circuit 2

The hysteresis can be set symmetrically or one-sided at the setpoint (see [46]). At one-sided setting, the hysteresis works downward with heating contact and upward with cooling contact. At symmetrical hysteresis, half of the hysteresis' value is effective below and half of the value above the switching point.

[46]: Hysteresis mode control circuit 3

These parameters allow selection as to whether the hysteresis values which are adjustable with [45], are set symmetrically or one-sided at the respective switching point.

Parameter description

At symmetrical hysteresis, half of the hysteresis' value is effective below and half of the value above the switching point. The one-sided hysteresis works downward with heating contact and upward with cooling contact.

[47: Minimum action time control circuit 2 "On"

[48: Minimum action time control circuit 2 "Off"

These parameters permit a delay in switching on/off the relay, in order to reduce the switching frequency. The adjusted time sets the entire minimum time period for a switching-on or switching-off phase.

[49: Function control circuit 3 at sensor error

At sensor error the selected relay (see [H41](#), [H42](#)) falls back into the condition pre-set here.

[61: Lower alarm value

[62: Upper alarm value

The exit alarm is a boundary alarm or a range alarm with one-sided hysteresis (see parameter [\[65\]](#)). Both at the boundary alarm and the range alarm, limit values can be relative, i.e. going along with the setpoint [\[1\]](#)/[\[2\]](#), or absolute, i.e. independent of the setpoint [\[1\]](#)/[\[2\]](#). At boundary alarm the hysteresis works one-sided inwardly, and at range alarm outwardly (see pictures).

[63: Function exit alarm

The exit alarm evaluates an upper and a lower limit value (see parameters [\[61\]](#) and [\[62\]](#)), whereas a selection is possible as to whether the alarm is active if the temperature lies within these two limits, or whether the alarm is released if the temperature lies beyond them. In the case of sensor error, the alarm is activated independently of this adjustment. The exit can also be inverted, so that it functions like a release (see pictures).

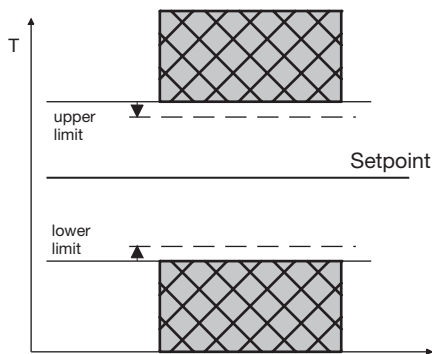

Boundary alarm, alarm contact normal:
[\[63\]=0](#) limits relative, [\[63\]=1](#) limits absolute

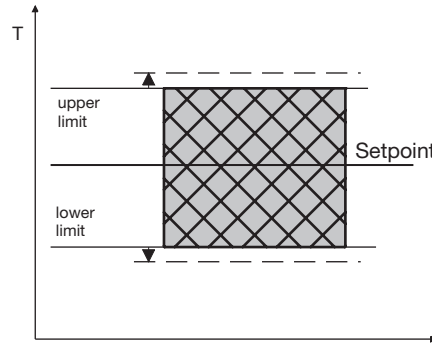

Range alarm, alarm contact normal:
[\[63\]=2](#) limits relative, [\[63\]=3](#) limits absolute

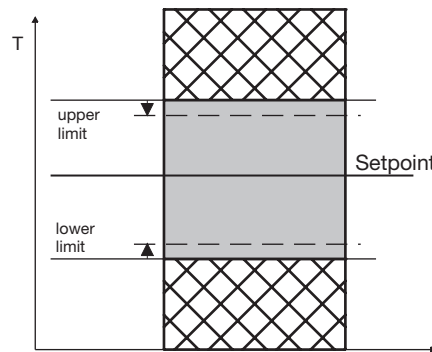

Boundary alarm, alarm contact inverse:
[\[63\]=4](#) limits relative, [\[63\]=5](#) limits absolute

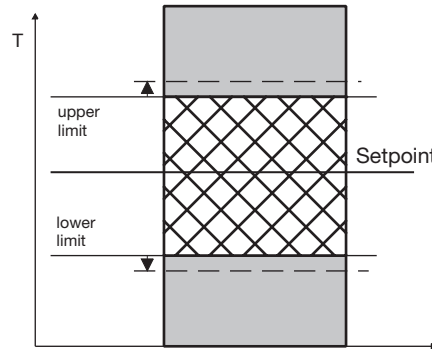

Range alarm, alarm contact inverse:
[\[63\]=6](#) limits relative, [\[63\]=7](#) limits absolute

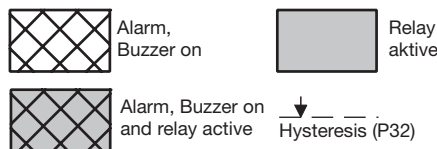

[64: Special function at alarm

Here can be selected whether, in the case of emergency, the indication to flash and/or the buzzer is to start. Sensor alarm (display F1L or F1H) is indicated independently thereof by flashing display and the buzzer runs off.

[65: Hysteresis alarm circuit

Hysteresis is set one-sided at the adjusted limit value. It becomes effective depending on alarm definition.

[99: Password

This parameter is to set the password for the [\[--\]](#) level.

b-level

b1: Activation setpoint combination for thermostat 1 and thermostat 2 (deltaW2)

This parameter determines whether the setpoints for thermostat 1 and 2 independently adjustable (parameter [\[21\]](#)) or whether they are tied with one another via a switching off-set deltaW2 (parameter [\[23\]](#)).

b2: Activation setpoint combination for thermostat 1 and thermostat 3 (deltaW3)

This parameter determines whether the setpoints for thermostat 1 and 3 independently adjustable (parameter [\[41\]](#)) or whether they are tied with one another via a switching off-set deltaW2 (parameter [\[43\]](#)).

b11: Delay control circuit 1, 2, 3 after "Power-On"

This parameter allows a switching-on delay of relays after switching-on the mains voltage. This delay corresponds with the time set here.

b12: Mutual delay control circuit 1, 2, 3

This parameter makes a mutual switching-on delay of relays possible, depending on whichever contact is switched first.

b13: Alarm suppression after "Power-On", "setpoint"

This parameter allows a switching-on delay of the alarm contact after switching on the mains voltage. This delay corresponds with the time set here.

b99: Password

This parameter is to set the password for the b-level.

H-level

H1: Key-lock

The key-lock allows blocking of the control keys. In locked condition parameter adjustments with keys is not possible. At the attempt to adjust the parameters despite key-lock the message "----" appears in the display.

H11: Indication mode display 1

The value can be indicated in integrals or with decimals in 0.5°K or 0.1°K. At indication in 0.5°K the value is rounded up or down. In general, all parameter indications are presented in 0.1°K.

H12: Display 1 mode

[H12=1](#) indicates the actual value and [H12=2](#) indicates the setpoint [\[1\]](#) or [\[2\]](#) in the display. Therefore, the current actual value can only be indicated with parameter [R1](#).

H 15: Temperature scale

Indication can be switched between Fahrenheit and Celsius. At conversion, the parameters and setpoints maintain their numerical value and adjustment range. (Example: A controller with the setpoint of 0°C is switched to Fahrenheit. The new setpoint is then interpreted as 0°F, which corresponds to a temperature of -18°C).

NOTE: Indication limits with °F can be smaller than the actual measuring range!

H 16: Indication standby

In standby mode the here set value appears in the display.

H 17: Mode following "Power-On"

After switching on the mains voltage, the controller automatically goes to the condition set here. H 17=2 applies to the condition prior to the separation from the net.

H3 1...H33: Assigning function key 1...3

Setting H3 1=0 deactivates the key, H3 1=1 functions as standby key.

H3 1=2 thus allows to change between setpoint 1 (E 1) and setpoint 2 (E 2).

H35: Key acknowledgement

This parameter permits to switch the internal buzzer on/off by key confirmation.

H4 1: Function output K1

H42: Function output S2

Generally, the exits are exchangeable with parameter adjustments, in order to achieve an optimal relation of the existing hardware with regard to contact rating, kind of contact and cycle number. Therefore, these parameters first assign the exits to the controller function.

H5 1: Mains frequency

This parameter is to select the mains frequency.

H6 1...H63: Function LED1-LED3

Assignment of the status LEDs.

H99: Password

This parameter is to adjust the password for the H-level

d-level:

d0: Defrosting interval

The "defrosting interval" defines the time, after which a defrosting process is started. After each defrosting start, this time is reset and runs the next interval.

Manual defrosting:

Pressing the key UP for at least 3 sec. the defrosting interval is activated earlier. Alternatively, parameter d9 can be applied for this function, too. The next automatic defrosting process takes place again after the time d0 (defrosting synchronisation).

d2: Defrosting temperature

This permits to terminate defrosting when the adjusted desired temperature value is reached. The defrosting time set with "d3" nevertheless runs at the same time, i.e. it functions as safety net to terminate the defrosting process in case the defrosting temperature is not reached.

d3: Defrosting time limit

After the here set time the defrosting process is terminated.

d9: Manual defrosting

At change of 0 -> 1 the defrosting process is started and the defrosting interval is re-set (defrosting synchronisation).

d99: Password

This parameter is to set the password for the d-level.

A-level:

A 1: Indication of actual value sensor F1

The here indicated temperature value is the sum of the actual measured value of sensor F1 and the actual value correction according to parameter A2.

A2: Actual value correction sensor F1

With this parameter it is possible to correct actual value deviations caused by sensor tolerances or extremely long sensor lines for example. The control measuring value is increased or decreased by the here set value.

A3: Weighing factor sensor F1

With this parameter the actual value can be submitted to weighing. The measured value is multiplied by it and both indicated in the display and applied for regulation.

A4: Sensor type F1

This parameter allows the selection of the sensor type or the type of analogue input as long as the hardware requirements are met.

A 17: Reset MIN/MAX memory

The MIN and/or MAX value can be reset.

A 18: Show actual MAX value

The current MAX value can be viewed here.

A 19: Show actual MIN value

The current MIN value can be viewed here.

A40: Software filter

This parameter determines over how many measured values an average value is to be formed. An average value is formed from the last measured values, whereby the oldest measured value is deleted (so-called "moving average filter").

A99 Password

This parameter is to set the password for the A-level.

Z level:

J1: Internal: active data set

With this parameter, you can set up pre-defined data sets. The data sets are provided by Störk-Tronic. If a new data set is loaded, all previously set parameters will be overwritten. After that, they can be edited as required.

J3: Parameter reset

With this parameter some parameters can be reset to factory defaults.

1: all control parameters

2: like 1, with counters and operating times

3: factory preset

L0: ST-bus own address

With the address set here, the controller can be addressed via the bus. Each bus client must have its own address. Addresses must be unique, i.e. must not be assigned several times.

L40: Mask on enabled functions

Here, you can specify the functions enabled via the bus using a binary mask. The bits have the following meaning

| Bit | Valency | Function |
|-----|---------|---------------|
| 0 | 1 | All On |
| 1 | 2 | Defrost |
| 2 | 4 | Acknowledge |
| 3 | 8 | Set2 absolute |
| 4 | 16 | Set3 relative |
| 5 | 32 | Min Reset |
| 6 | 64 | Max Reset |
| 7 | 128 | — |

To determine the value to be parametrised, all valencies must be added up

L42: 10 minutes release to reset counters and operating times

As soon as the parameter is set to 1, counters and operating times can be reset by means of parameters N98 and T98 during the following 10 minutes.

Z98: Password for level selection (if PA is displayed)

With this parameter, you can set the level selection password, i.e. in display PA. In the standard design, access to level selection is blocked by password - 19. This parameter cannot be set on the controller itself but only via the ST-bus

Z99: Password for Z-level

With this parameter, you can set the password for parameter level Z-.

| Message | Cause | Error elimination |
|-------------------------|---|-------------------|
| F 1H F 1L | Sensor error (H: open-circuit or L: short-circuit at sensor F1) | Check sensor |
| F2H F2L | Sensor error (H: open-circuit or L: short-circuit at 3-wire correction) | Check sensor |
| EP0 EP1 | 0: Error program memory 1: Error parameter memory => ALL EXITS WILL BE SWITCHED OFF | Repair controller |
| bot | Message if start update the controller via ST-Bus | |
| --- | Display overrun or key-lock | |
| Flashing display | Temperature alarm at too high or too low temperature (if activated) | |

If an error is detected in the parameter memory (display **EP**) and therefore the stored settings cannot be used, the control contacts are switched to the de-energised state.

Technical data

| | |
|---------------------------|--|
| Measuring input | F1: Resistance sensor PTC, Pt100, 2-wire connection Measuring range: Pt100 -80°C...+400 °C PTC -50°C...+150 °C Measuring accuracy of the controller at 25°C: +/-0.5K and +/-0.5% of measuring range |
| Outputs | K1: Relay, 16(2)A 250V, normally-open contact S2: Voltage output for SSR relay, output voltage 0/12V= Additional buzzer, 85dB |
| Display | One 3-digit LED-Display, height 7 mm, colour red |
| Power supply | 100...240V AC, (50/60Hz) |
| Connectors | Screw terminal |
| Ambient conditions | Storage temperature: 20...+70 °C Operating temperature: 0...+55 °C Relative humidity: max. 75% without dew |
| Enclosure | Front IP65, IP00 from back |
| Interface | ST-Bus communication interface Interface driver: RS485, galvanically not separated The network has to be installed in lines topology and terminated with a 120 Ohm resistance on each side. In case of networking always connect port "A" with port "A" and port "B" with port "B". Crossing over is not permissible! |
| Installation data | The controller is designed for installation in a control panel. Front size: 107 x 24 mm Panel cut-out: 73 x 22.4 mm Installation depth max. 65mm |

